

# Move as

- Mobile Trender 28/8-2014
- Mobil videokonferanse



**Leif B. Paulsen**

**[Lbp@move.no](mailto:Lbp@move.no)**

**T-92253308**

# Innhold

---

## Nye muligheter innenfor videokonferanse, åpner for nye mobile løsninger og arbeidsformer

- Status Videokonferanse i norske virksomhetene
- Nye standarder og nye enheter gir nye muligheter
- Trender og økosystem som forsterker utviklingen
- Sett dette før? Analogi til andre skifter i teknologi
- Integrasjon med eksisterende løsninger
- Kapasitet? Skalering i store miljøer
- Krav til underliggende infrastruktur
- Tilgang til teknologi og leveransemodeller i markedet
- Kort demonstrasjon
  - Brukeropplevelse og integrasjon
- Bruksområder og muligheter for bedriftsmarkedet

# Sammenheng arbeidsform og arbeidsvilkår

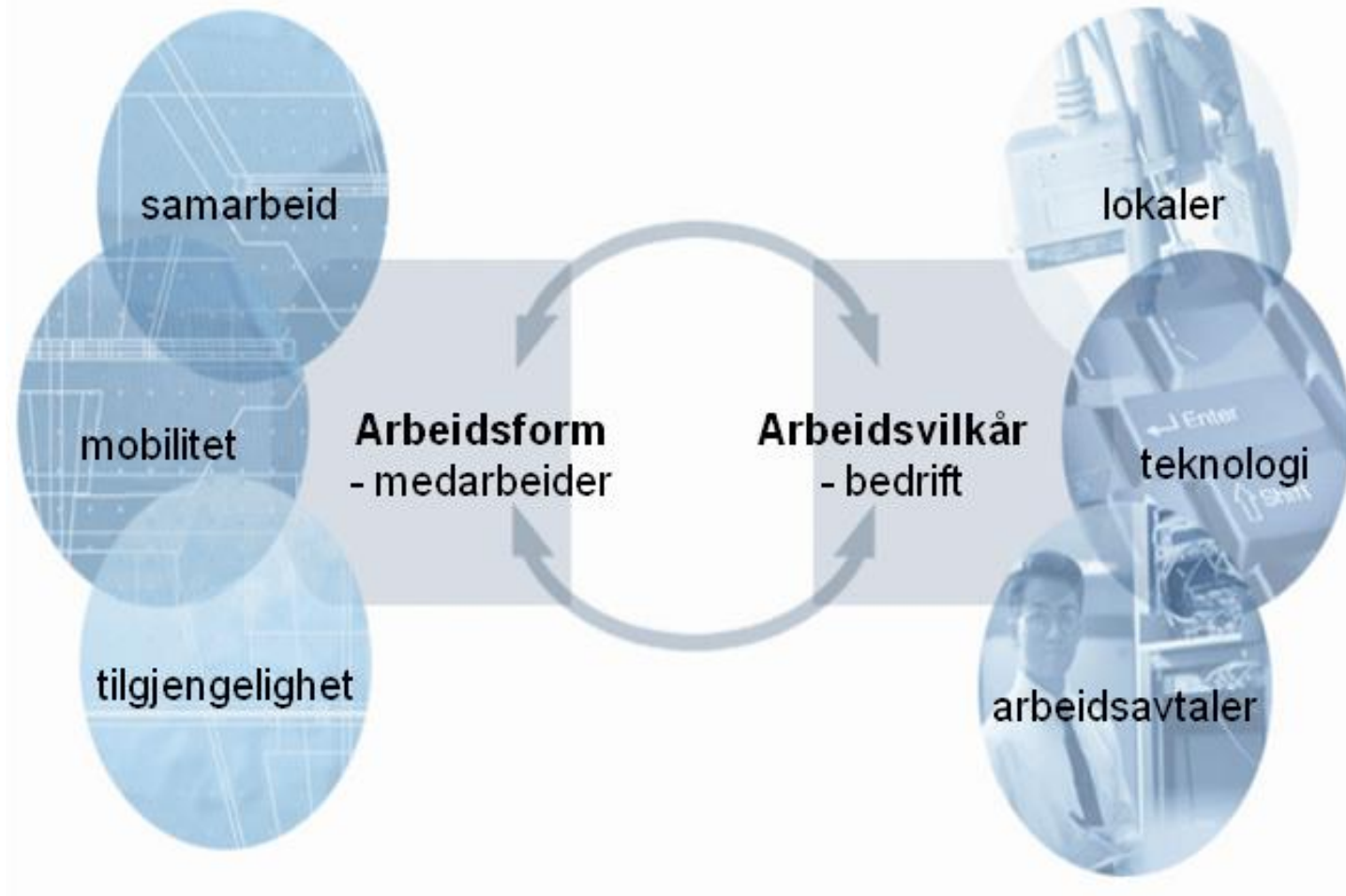

# Møtestruktur i et utvalg norske bedrifter



## Effektive møter?

- 22 % av arbeidstiden brukes til møter, 32 % i off. sektor.
- Omlag en femtedel av møtetiden oppleves som bortkastet tid. (tas ledere/møteledere ut at datagrunnlaget, er tallet om lag en tredjedel av møtetiden)
- Tidsbruk i møter forlenger arbeidsdagen.
- Korte møter er mer effektivt enn lange møter.
- Ledere bruker over halve arbeidsdagen i møter og har lengre møter.

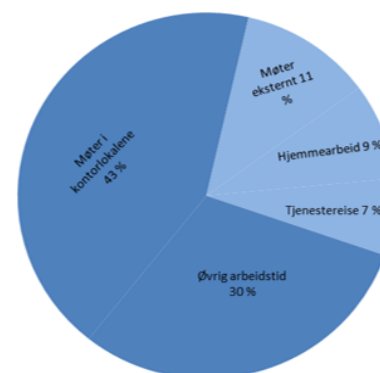
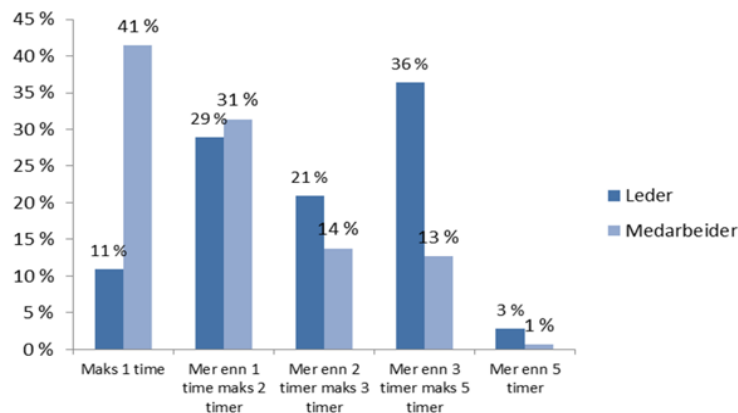

Utvalgstrekk: 3533 medarbeidere i store og mellomstore off. og private virksomheter (Company Pulse 2013)

# Effektivitet i videomøter



Innledning

Sammendrag

Arbeidsdag og tidsbruk

Kontorløsninger

Datautstyr

Kommentarer

Demografi

## Effektive videomøter?

- 10 % av møtetiden er videokonferanse, kun 4 % i offentlig sektor.
- Videomøter er i gjennomsnitt noe kortere «ansikt til ansikt» møter.
- Videomøter er mer effektive – deltakerne oppgir bedre nytteverdi
- Færre deltakere i møtene.
- Reduserer reisevirksomhet for minst en av deltakere, både tjenestereiser og pendlerreiser.
- Store forskjeller mellom virksomheter, også innad i samme bransje og i samme organisasjon! Nødvendig å kartlegge situasjonen i din bedrift.



# Brukereksempel fra undersøkelsene



## Eksempel



### Mer effektive møter i IF Skadeforsikring!

I følge Company Pulse utgjorde fjernmøter totalt sett hele 52% av møtetiden! Effekten var at langt mindre tid ble brukt til å reise til og fra møter. Det viste seg også at fjernmøter har noe kortere varighet enn fysiske møter.

***“For IF var det svært gledelig å kunne dokumentere en slik positiv utvikling”.***



Trude Harneshaug, Office Manager, IF



For dyrt, bare for ledelsen



Dårlig opplevelse flue på veggen



Låst til kontoret



Rommet opptatt

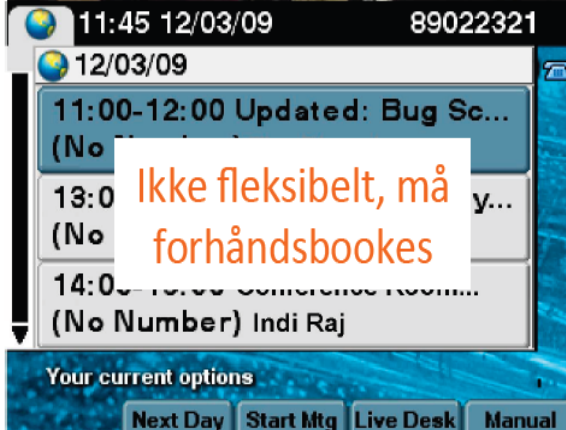

Ikke fleksibelt, må forhåndsbookes



Dårlig kvalitet



Inkompatible systemer



Vanskelig å bruke



Ønsker å reise

# Målbilde

## Høykvalitets videokonferanse uten «begrensninger»





# Skifte i teknologi

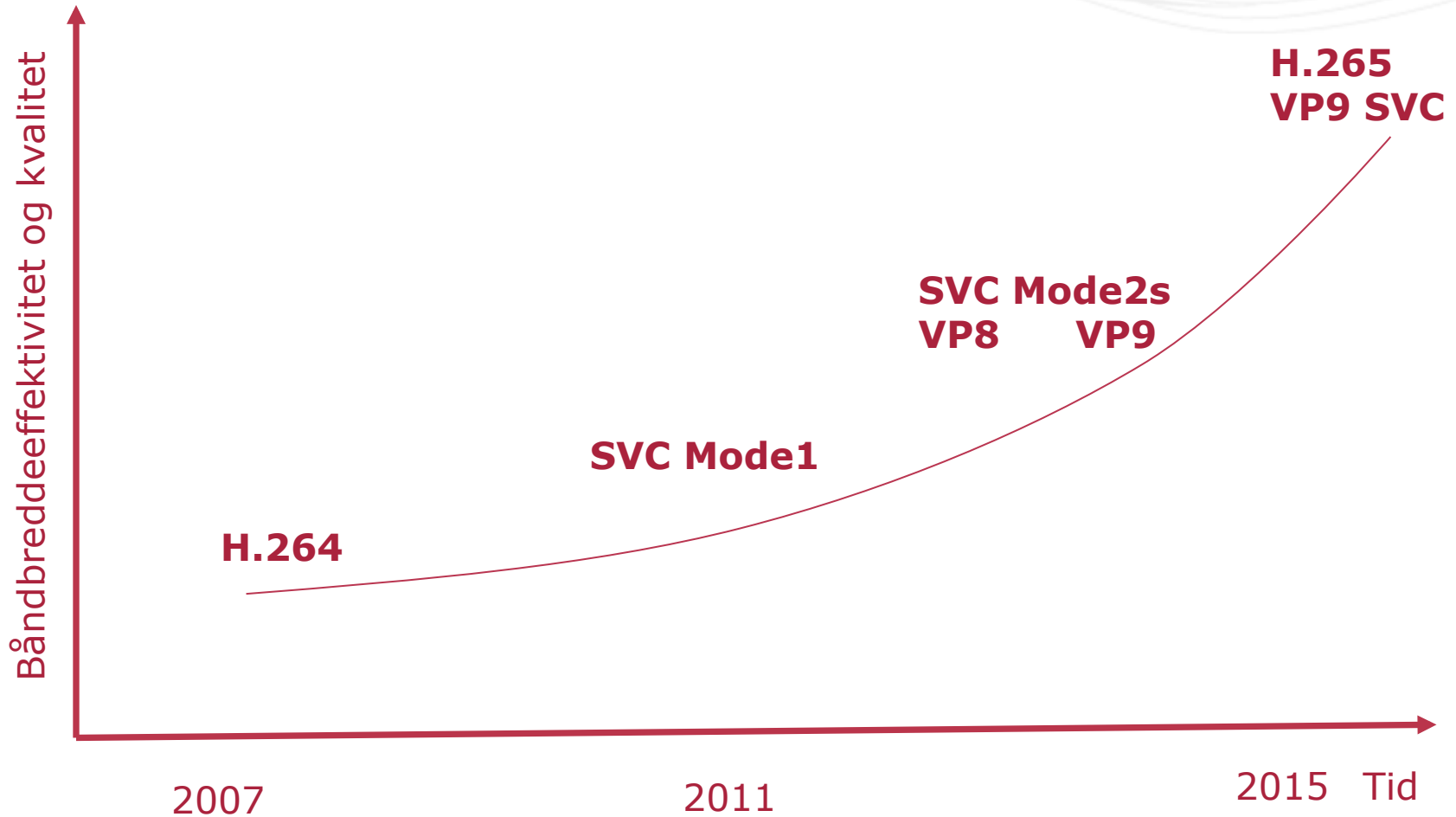

# Teknologiutviklingen

Båndbreddeeffektivitet og kvalitet

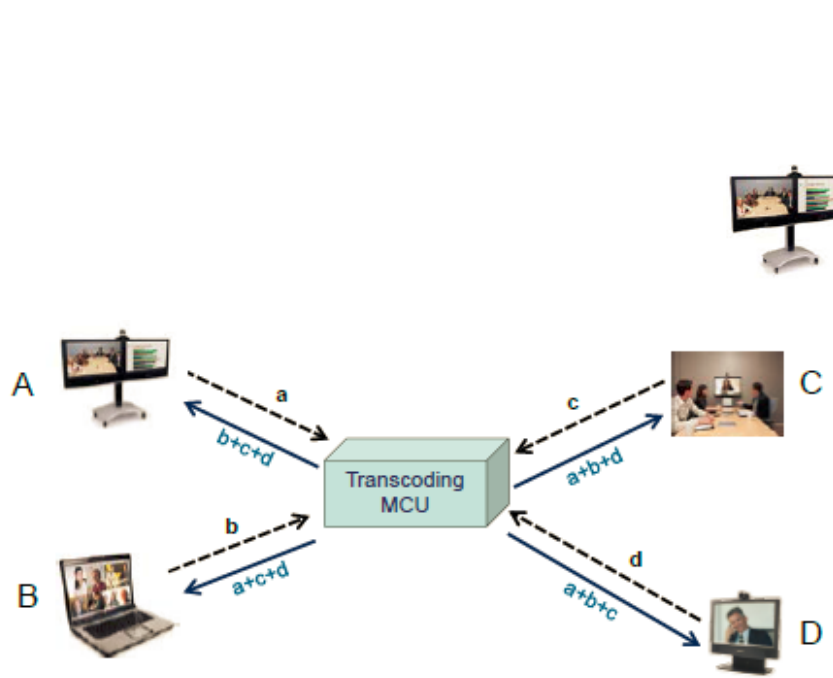

Figure 1: Multipoint call with a transcoding MCU. Note that each endpoint sends and receives ONE stream.

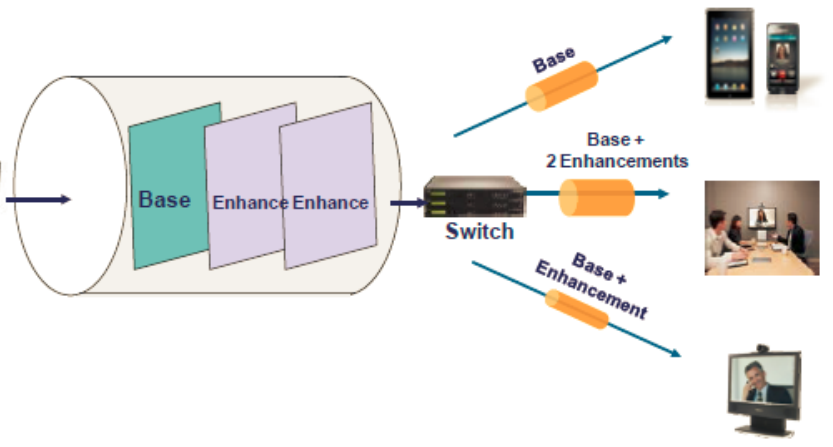

Figure 3: SVC uses base layer and enhancement layers

2007

2011

2015 Tid

# Teknologiskifte eller noe som ligner.....

---



# Endepunkter eksploderer i antall og kvalitet

Skaleringsutfordring

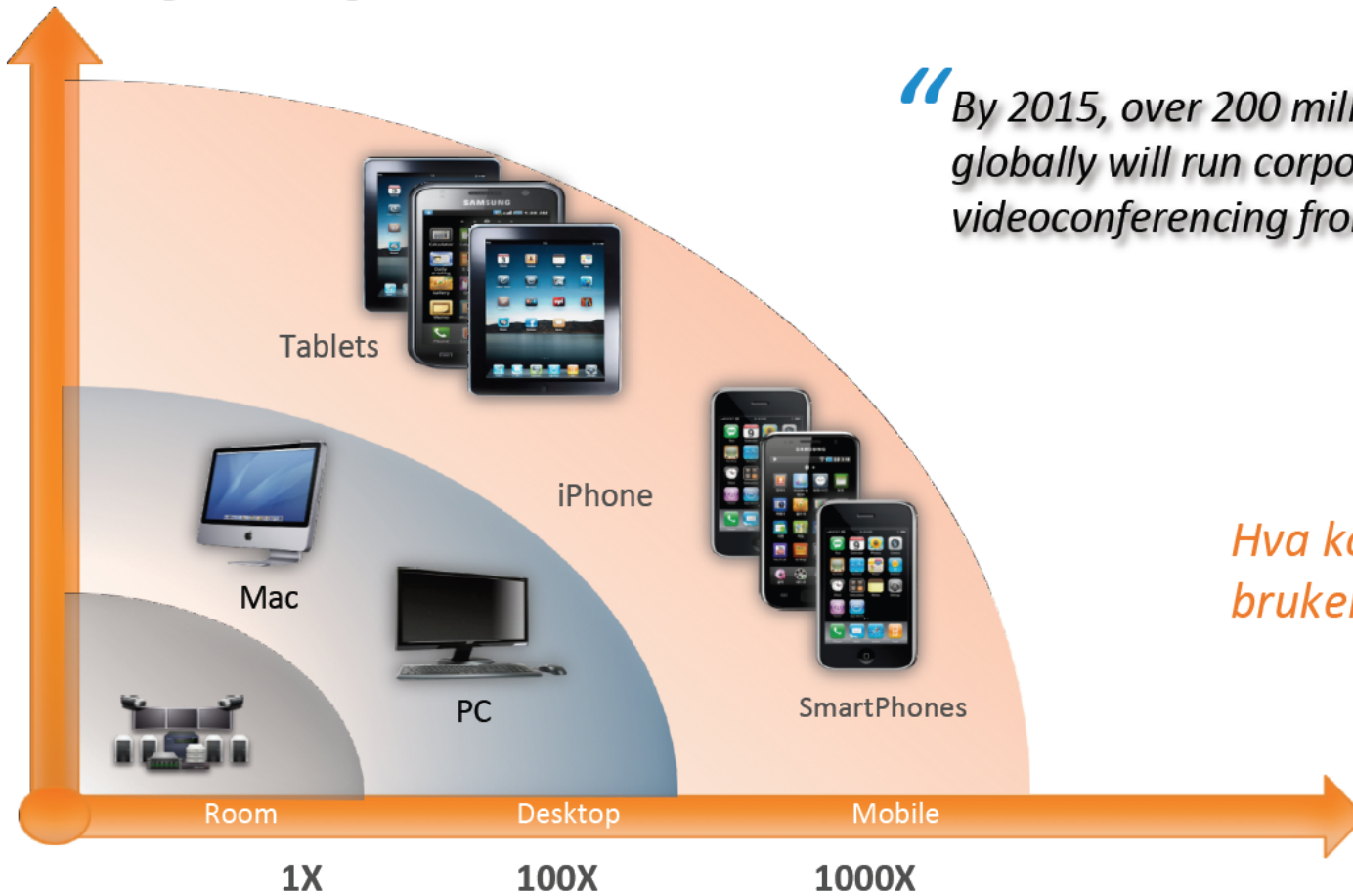

“ By 2015, over 200 million workers globally will run corporate-supplied videoconferencing from their desktops. ”

– Gartner,  
ID Number: G00173005

*Hva koster MCU-porter og brukerlisenser til alle ansatte?*

Antall video-endepunkter

# Liten eller ingen kontroll på nettkvaliteten

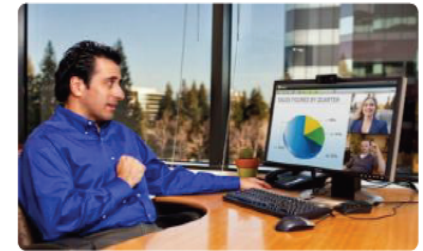
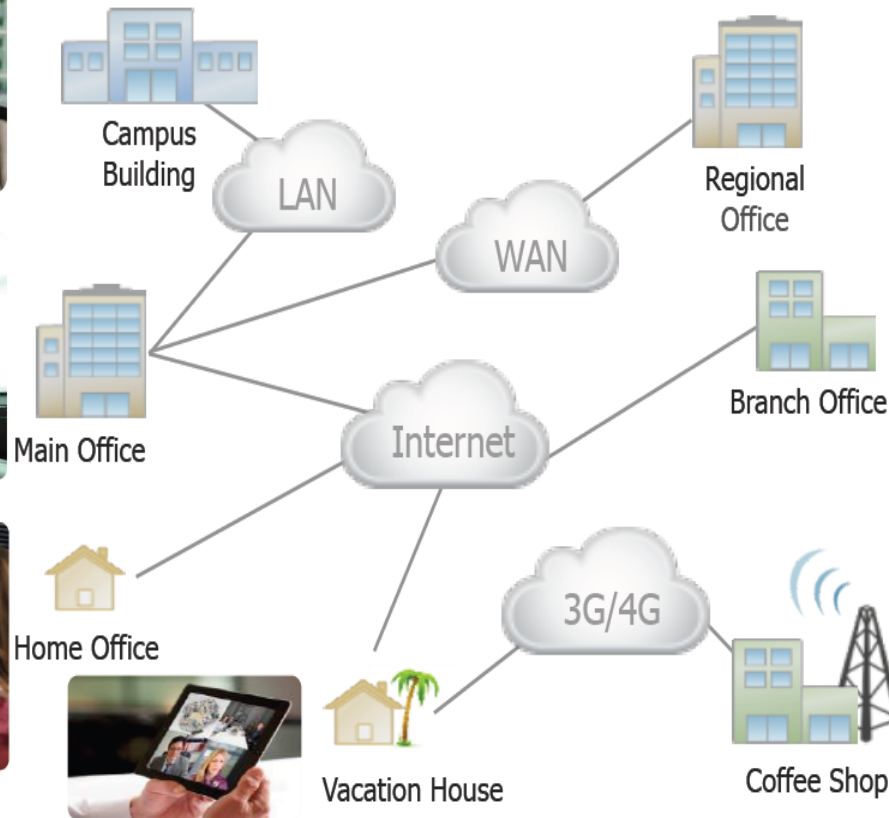

# AV produsentene bidrar til nye muligheter



# Kunnskapssamfunnet er organisert annerledes

---

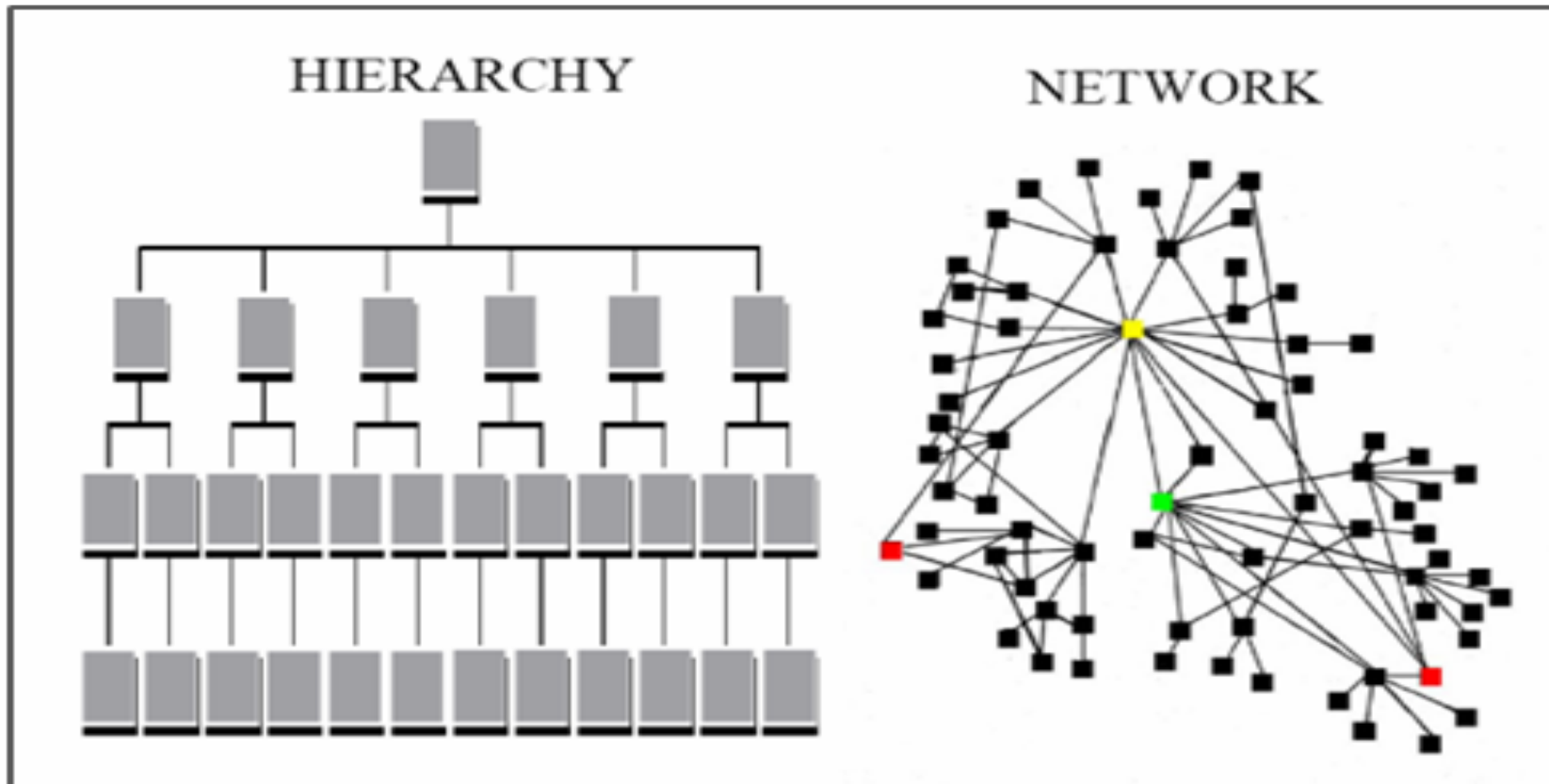

# Tradisjonell PABX til IP og Mobiltelefoni

- Fra Hardware til Software løsninger
- Fra stasjonært til mobilt

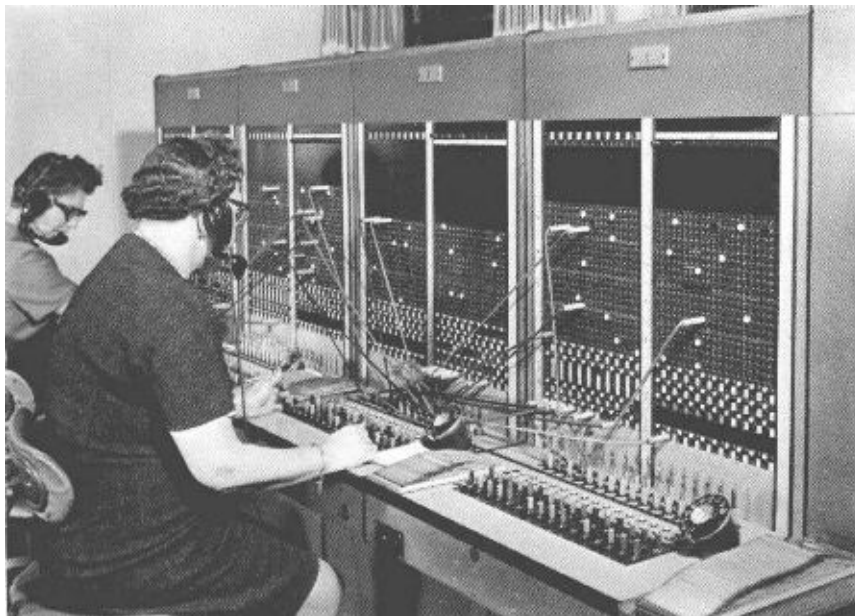



# Fra hjemmet til jobben - Consumerization

- Grafisk brukergrensesnitt
- Trådløst nettverk
- Smarttelefonen
- Nettbrett
- Mobil Videokonferanse



# Integrasjon er en forutsetning nå!

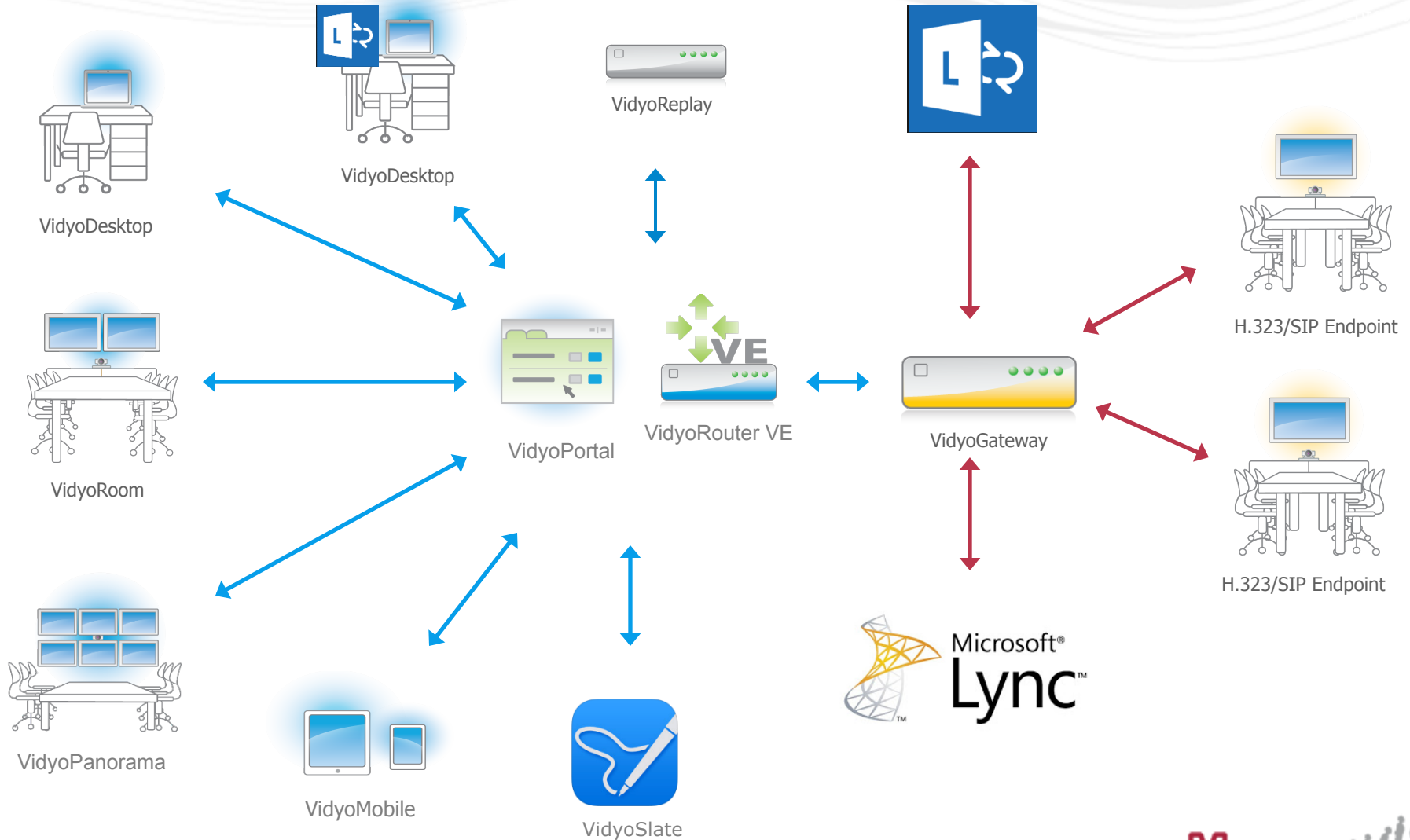

# Eksempel videokonferanse integrert i kalender

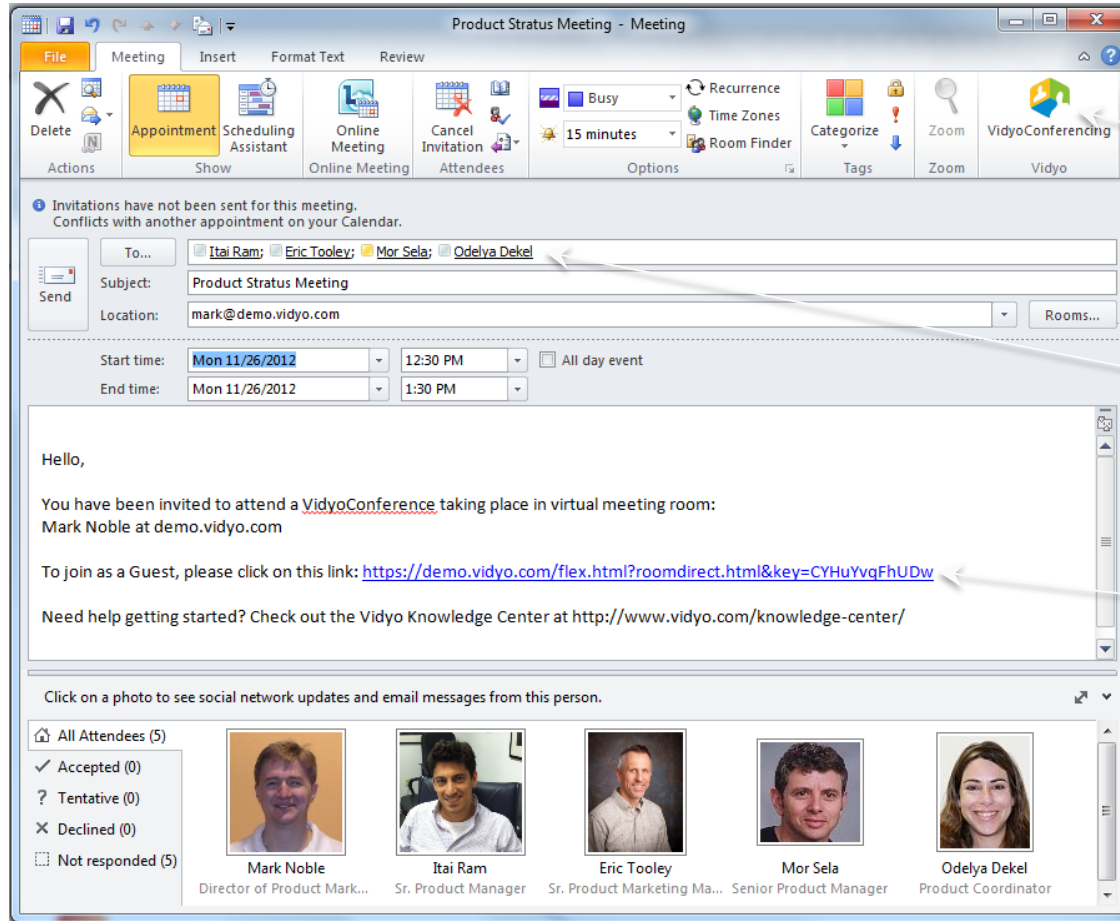

1

Add Vidyo to a meeting with a 'Single Click'

2

Common contact list with email, IM, voice

3

'Click-to-Connect' link for guest participants



# Leveransmodeller i markedet



On Premise



Private Cloud



Public Cloud

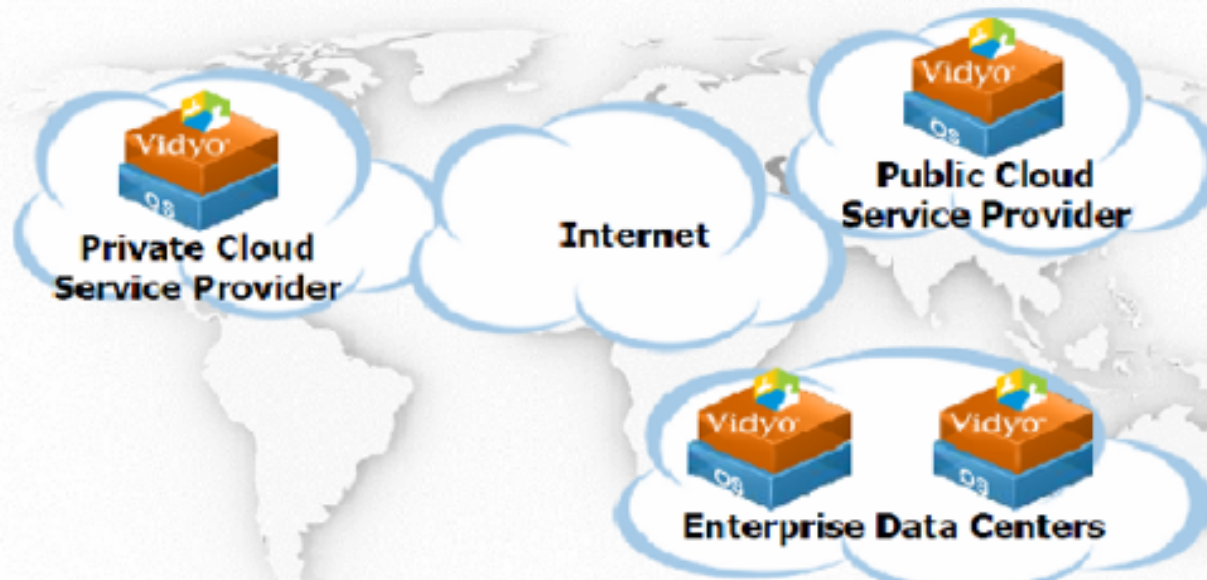

# Cern – Mobil video i stort omfang



## CERN supports:

- 20,000 Scientists for Mass Global Collaboration on High-Energy Physics Research and LHC Experiments
- Over 600 Institutes and Universities Across 113 Countries
- Peaks of 750 concurrent users
- 2000-3000 connections per day

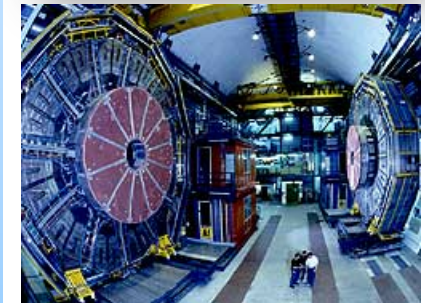
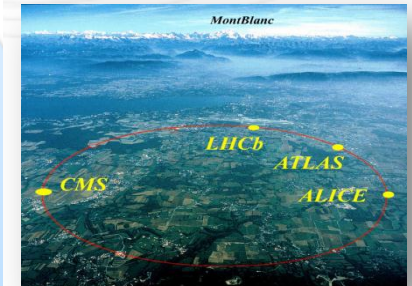

<http://avc-dashboard.web.cern.ch/Vidyo>

# Demo

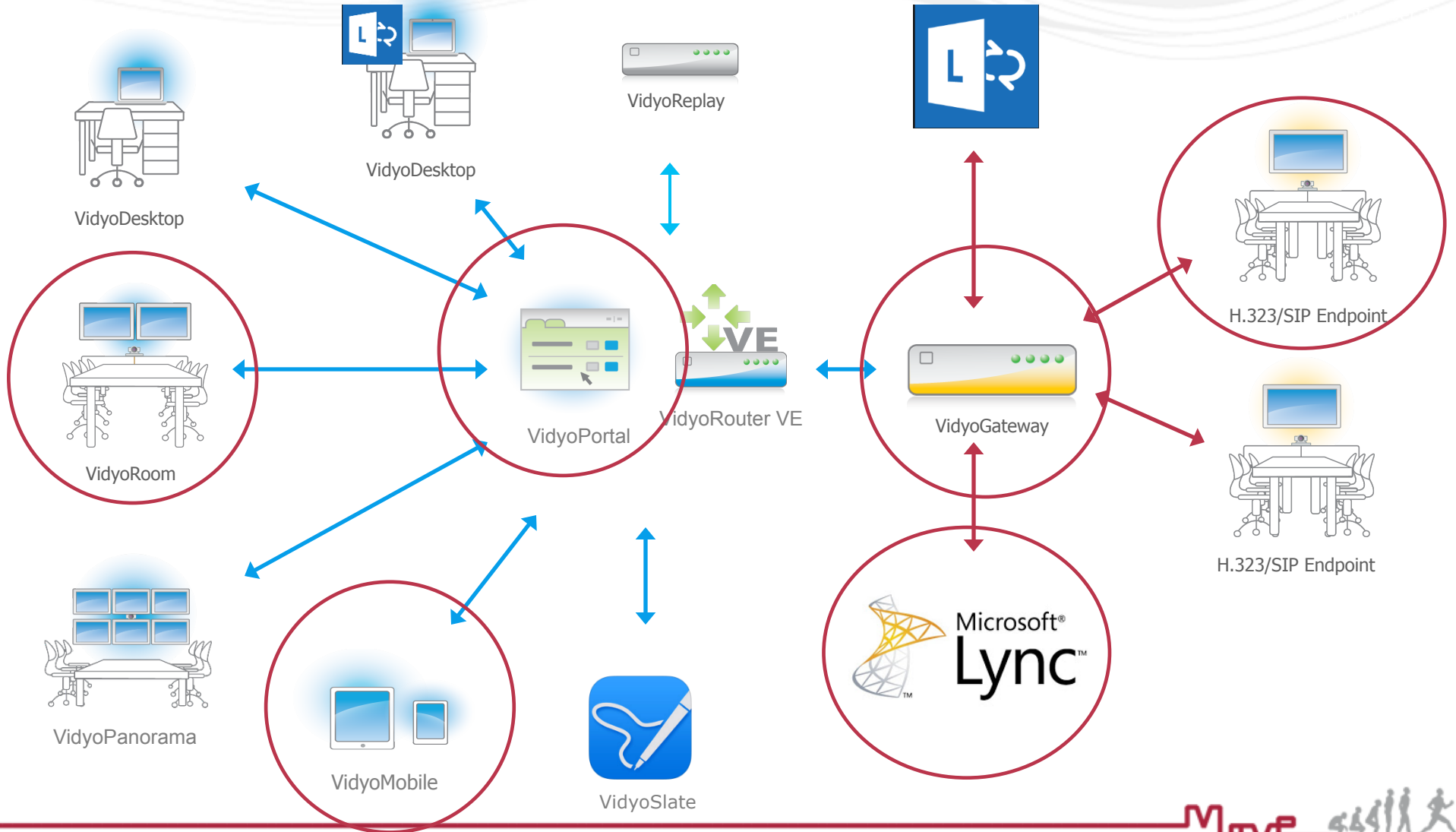

# KPMG Norway

---



- **900-1500 Personlig Video**
  - VidyoDesktop
  - Vidyo Mobile
- Integrasjon med CiscoRom
  - 25 Cisco Roms
- Nye Møterom er VidyoRom

# «Video Enabled Workforce»

Opplæring

Tilgang  
Kompetanse

Forhandlinger

Problemløsning

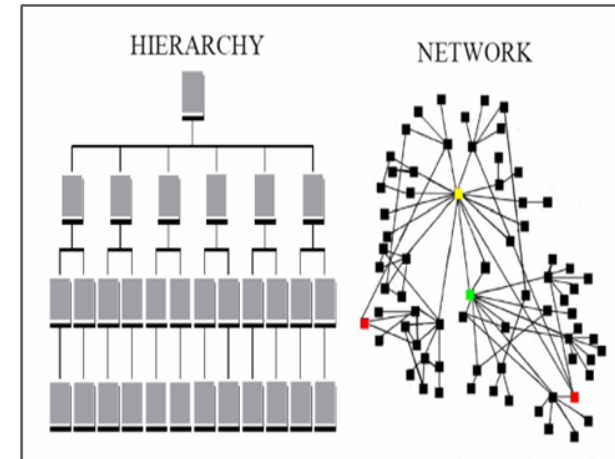
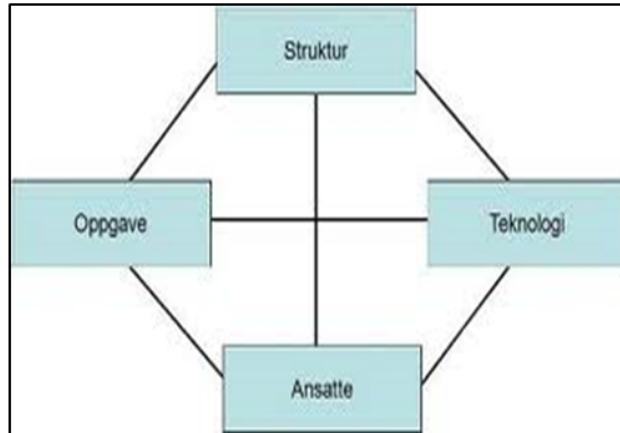

Ledelse

Salgsarbeid

Tilhørighet

Informasjon